



# ROUSH 2010+ 6.2L F-150 R2300 TUNER Supercharger Kit



**PART NUMBER:** 421245

**DESCRIPTION:** 2010+ 6.2L F-150 R2300 TUNER Supercharger Kit (Without Calibration)

**PRICING:**

MSRP: \$6,199.99

**FEATURES:**

- R2300 Supercharger featuring Eaton's new TVS Technology. The new Twin Vortices Series features four-lobe rotors with high-flow inlet and outlet ports that greatly enhance thermal efficiency, enabling greater volumetric capacity at higher revolutions per minute (RPM)
- High efficiency intercooler system featuring dual-core low temp radiator, degas bottle, high capacity air-to-water intercooler and formed hoses with abrasion-resistant sleeves
- Twin 60mm throttle body and 100mm MAF housing
- High-flow cold air induction
- Integrated bypass valve to increase fuel efficiency
- Capable of producing over 700 Horsepower
- Kit does not include calibration, fuel injectors or spark plugs
- 90-Day Parts warranty included (ROUSH Supplied Parts Only)
- NOT approved for sale or installation in the state of California

**APPLICATIONS:**

- 2010+ 6.2L F-150 4x2
- 2010+ 6.2L F-150 4x4

**SHIPPING WEIGHTS & DIMENSIONS:**

Weight (Box 1)= 62 lbs

Dimensions = 32" x 13" x 32"

Weight (Box 2)= 41 lbs

Dimensions = 26" x 20" x 17"

Weight (Box 3)= 32 lbs

Dimensions = 26" x 16" x 11"

**UPDATED:** January 2, 2012

**800-59-ROUSH**

**www.ROUSHperformance.com**



# ROUSH 2011+ 5.0L F-150 R2300 CALIBRATED Supercharger Kit



**PART NUMBER:** 421244

**DESCRIPTION:** 2011+ 5.0L F-150 R2300 CALIBRATED Supercharger Kit

**PRICING:**

MSRP: \$6,499.99

**FEATURES:**

- R2300 Supercharger featuring Eaton's new TVS Technology. The new Twin Vortices Series features four-lobe rotors with high-flow inlet and outlet ports that greatly enhance thermal efficiency, enabling greater volumetric capacity at higher revolutions per minute (RPM)
- High efficiency intercooler system featuring dual-core low temp radiator, degas bottle, high capacity air-to-water intercooler and formed hoses with abrasion-resistant sleeves
- Twin 60mm throttle body and 100mm MAF housing
- High-flow cold air induction
- 1st sheave FEAD system with heavy duty tensioner for greater durability
- Integrated bypass valve to increase fuel efficiency
- Estimated 500-525 horsepower target (up from 360 horsepower stock) / 140-165 hp gain
- Kit includes ROUSH calibration, 47lb fuel injectors and spark plugs
- 3 yr / 36,000 mile parts warranty included (ROUSH Parts) - Optional complete drivetrain warranty available (\$375)
- NOT approved for sale or installation in the state of California

**APPLICATIONS:**

- 2011+ 5.0L F-150 4x2
- 2011+ 5.0L F-150 4x4

**SHIPPING WEIGHTS & DIMENSIONS:**

Weight (Box 1)= 62 lbs  
Weight (Box 2)= 41 lbs  
Weight (Box 3)= 32 lbs

Dimensions = 32" x 13" x 32"  
Dimensions = 26" x 20" x 17"  
Dimensions = 26" x 16" x 11"

**UPDATED:** January 2, 2012

**800-59-ROUSH**

**www.ROUSHperformance.com**



# ROUSH 2011+ 5.0L F-150 R2300 TUNER Supercharger Kit



**PART NUMBER:** 421243

**DESCRIPTION:** 2011+ 5.0L F-150 R2300 TUNER Supercharger Kit (Without Calibration)

**PRICING:**

MSRP: \$6,199.99

**FEATURES:**

- R2300 Supercharger featuring Eaton's new TVS Technology. The new Twin Vortices Series features four-lobe rotors with high-flow inlet and outlet ports that greatly enhance thermal efficiency, enabling greater volumetric capacity at higher revolutions per minute (RPM)
- High efficiency intercooler system featuring dual-core low temp radiator, degas bottle, high capacity air-to-water intercooler and formed hoses with abrasion-resistant sleeves
- Twin 60mm throttle body and 100mm MAF housing
- High-flow cold air induction
- 1st sheave FEAD system with heavy duty tensioner for greater durability
- Integrated bypass valve to increase fuel efficiency
- Capable of producing over 700 Horsepower
- Kit does not include calibration, fuel injectors or spark plugs
- 90-Day Parts warranty included (ROUSH Supplied Parts Only)
- NOT approved for sale or installation in the state of California

**APPLICATIONS:**

- 2011+ 5.0L F-150 4x2
- 2011+ 5.0L F-150 4x4

**SHIPPING WEIGHTS & DIMENSIONS:**

Weight (Box 1)= 62 lbs  
 Weight (Box 2)= 41 lbs  
 Weight (Box 3)= 32 lbs

Dimensions = 32" x 13" x 32"  
 Dimensions = 26" x 20" x 17"  
 Dimensions = 26" x 16" x 11"

**UPDATED:** January 2, 2012

**800-59-ROUSH**

**www.ROUSHperformance.com**



# 2011-2012 Ford F-150 3.7L-V6 / 6.2L-V8 SuperDuty ROUSH Cold Air Induction Kit

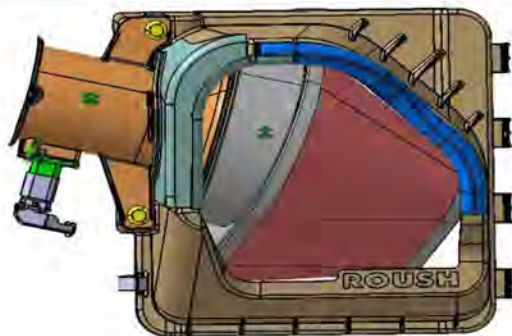

**PART NUMBER:** 421237 (3.7L-V6 / 6.2L Super Duty)

**DESCRIPTION:** 2011-2012 Ford F-150 3.7L-V6 / 6.2L Super Duty ROUSH Cold Air Induction Kit

**PRICING:**

MSRP: \$309.99

**FEATURES:**

- Easy to install - less than one hour and NO drilling or cutting required
- Washable, reusable premium high-flow air filter
- Injection-molded MAF tube and clean air box lid designed for maximum air flow efficiency
- Improved throttle response
- Increased performance and efficiency
- Increased fuel economy
- Superior structural capability, stability, and durability
- NOT approved for sale or installation in the state of California

**APPLICATIONS:**

- 2011-2012 Ford F-150 with 3.7L-V6 or 6.2L-V8 Super Duty engines
  - Includes all models available with the 3.7L-V6 engine or 6.2L gas Super Duty
  - Includes all bed and cab configurations

**KIT CONTAINS:**

- |                                   |   |
|-----------------------------------|---|
| (1) MAF Tube                      | (1) Upper Air Box Assembly              |
| (1) Premium Air Filter - Washable | (1) EPDM Seal - MAF Tube to Air Box Lid |
| (2) Bolt - M8 x 1.25 x 25         | (2) J-Clip M8 - MAF Tube to Air Box Lid |
|                                   | (1) Installation Manual                 |

**WEIGHTS & DIMENSIONS:**

Weight = TBD lbs

Dimensions = TBD" x TBD" x TBD"

**UPC CODE:** 84476421237

**UPDATED:** January 9, 2012

**800-59-ROUSH**

**rppsales@roush.com**

**www.ROUSHperformance.com**